

PRODUKTINFORMATION



HÄMTFAX
08-580 941 14



FAX ON DEMAND
+46 8 580 941 14



INTERNET
<http://www.elfa.se>

TEKNISK INFORMATION 020-75 80 20 ORDERTEL 020-75 80 00 ORDERFAX 020-75 80 10

TECHNICAL INFORMATION +46 8 580 941 15 ORDERPHONE +46 8 580 941 01 ORDERFAX +46 8 580 941 11

— Vi reserverar oss mot fel samt förbehåller oss rätten till ändringar utan föregående meddelande —

ELFA artikelnr.

73-003-79 OPA37GP op-först

73-004-11 OPA37GU op-amp SO8

73-004-37 OPA27GP op-amp

73-004-45 OPA27GU op-amp SO8

Antal sidor: 14

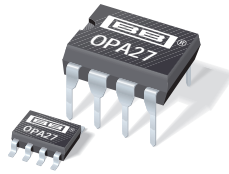

OPA27
OPA37

Ultra-Low Noise Precision OPERATIONAL AMPLIFIERS

FEATURES

- **LOW NOISE:** $4.5\text{nV}/\sqrt{\text{Hz}}$ max at 1kHz
- **LOW OFFSET:** $100\mu\text{V}$ max
- **LOW DRIFT:** $0.4\mu\text{V}/^\circ\text{C}$
- **HIGH OPEN-LOOP GAIN:** 117dB min
- **HIGH COMMON-MODE REJECTION:** 100dB min
- **HIGH POWER SUPPLY REJECTION:** 94dB min
- **FITS OP-07, OP-05, AD510, AD517 SOCKETS**

APPLICATIONS

- **PRECISION INSTRUMENTATION**
- **DATA ACQUISITION**
- **TEST EQUIPMENT**
- **PROFESSIONAL AUDIO EQUIPMENT**
- **TRANSDUCER AMPLIFIER**
- **RADIATION HARD EQUIPMENT**

DESCRIPTION

The OPA27/37 is an ultra-low noise, high precision monolithic operational amplifier.

Laser-trimmed thin-film resistors provide excellent long-term voltage offset stability and allow superior voltage offset compared to common zener-zap techniques.

A unique bias current cancellation circuit allows bias and offset current specifications to be met over the full -55°C to $+125^\circ\text{C}$ temperature range.

The OPA27 is internally compensated for unity-gain stability. The decompensated OPA37 requires a closed-loop gain ≥ 5 .

The Burr-Brown OPA27/37 is an improved replacement for the industry-standard OP-27/OP-37.

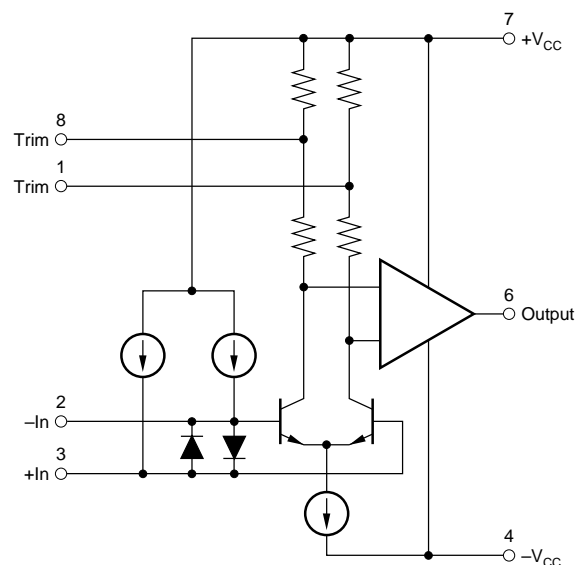

SPECIFICATIONS

At $V_{CC} = \pm 15V$ and $T_A = +25^\circ C$, unless otherwise noted.

PARAMETER	CONDITIONS	OPA27/37G			UNITS
		MIN	TYP	MAX	
INPUT NOISE ⁽⁶⁾ Voltage, $f_o = 10Hz$ $f_o = 30Hz$ $f_o = 1kHz$ $f_B = 0.1Hz$ to $10Hz$ Current, ⁽¹⁾ $f_o = 10Hz$ $f_o = 30Hz$ $f_o = 1kHz$			3.8	8.0	nV/\sqrt{Hz}
			3.3	5.6	nV/\sqrt{Hz}
			3.2	4.5	nV/\sqrt{Hz}
			0.09	0.25	$\mu Vp-p$
			1.7		pA/\sqrt{Hz}
			1.0		pA/\sqrt{Hz}
		0.4		0.6	pA/\sqrt{Hz}
OFFSET VOLTAGE ⁽²⁾ Input Offset Voltage Average Drift ⁽³⁾ Long Term Stability ⁽⁴⁾ Supply Rejection	$T_{A\ MIN}$ to $T_{A\ MAX}$		± 25	± 100	μV
			± 0.4	± 1.8 ⁽⁶⁾	$\mu V/^\circ C$
			0.4	2.0	$\mu V/mo$
		$\pm V_{CC} = 4$ to $18V$ $\pm V_{CC} = 4$ to $18V$	94	120 ± 1	± 20
BIAS CURRENT Input Bias Current			± 15	± 80	nA
OFFSET CURRENT Input Offset Current			10	75	nA
IMPEDANCE Common-Mode			2 2.5		$G\Omega$ pF
VOLTAGE RANGE Common-Mode Input Range Common-Mode Rejection	$V_{IN} = \pm 11VDC$	± 11	± 12.3		V
		100	122		dB
OPEN-LOOP VOLTAGE GAIN, DC	$R_L \geq 2k\Omega$ $R_L \geq 1k\Omega$	117	124		dB
			124		dB
FREQUENCY RESPONSE Gain-Bandwidth Product ⁽⁵⁾ Slew Rate ⁽⁵⁾ Settling Time, 0.01%	OPA27 OPA37 $V_O = \pm 10V$, $R_L = 2k\Omega$ OPA27, G = +1 OPA37, G = +5 OPA27, G = +1 OPA37, G = +5	5 ⁽⁶⁾	8		MHz
		45 ⁽⁶⁾	63		MHz
		1.7 ⁽⁶⁾	1.9		V/ μs
		11 ⁽⁶⁾	11.9		V/ μs
			25		μs
		25		μs	
RATED OUTPUT Voltage Output Output Resistance Short Circuit Current	$R_L \geq 2k\Omega$ $R_L \geq 600\Omega$ DC, Open Loop $R_L = 0\Omega$	± 12	± 13.8		V
		± 10	± 12.8		V
			70		Ω
			25	60 ⁽⁶⁾	mA
POWER SUPPLY Rated Voltage Voltage Range, Derated Performance Current, Quiescent	$I_O = 0mADC$		± 15		VDC
			± 4	± 22	VDC
			3.3	5.7	mA
TEMPERATURE RANGE Specification Operating		-40		+85	$^\circ C$
		-40		+85	$^\circ C$

NOTES: (1) Measured with industry-standard noise test circuit (Figures 1 and 2). Due to errors introduced by this method, these current noise specifications should be used for comparison purposes only. (2) Offset voltage specification are measured with automatic test equipment after approximately 0.5 seconds from power turn-on. (3) Unnulled or nulled with 8k Ω to 20k Ω potentiometer. (4) Long-term voltage offset vs time trend line does not include warm-up drift. (5) Typical specification only on plastic package units. Slew rate varies on all units due to differing test methods. Minimum specification applies to open-loop test. (6) This parameter guaranteed by design.

SPECIFICATIONS

At $V_{CC} = \pm 15V$ and $T_A = +25^\circ C$, unless otherwise noted.

PARAMETER	CONDITIONS	OPA27/37G			UNITS
		MIN	TYP	MAX	
INPUT VOLTAGE ⁽¹⁾ Input Offset Voltage Average Drift ⁽²⁾ Supply Rejection	$T_{A\ MIN}$ to $T_{A\ MAX}$ $\pm V_{CC} = 4.5$ to $18V$ $\pm V_{CC} = 4.5$ to $18V$		± 48 ± 0.4	$\pm 220^{(3)}$ $\pm 1.8^{(3)}$	μV $\mu V/^\circ C$ dB
BIAS CURRENT Input Bias Current			± 21	$\pm 150^{(3)}$	nA
OFFSET CURRENT Input Offset Current E, F, G			20	$135^{(3)}$	nA
VOLTAGE RANGE Common-Mode Input Range Common-Mode Rejection	$V_{IN} = \pm 11VDC$	$\pm 10.5^{(3)}$ $96^{(3)}$	± 11.8 122		V dB
OPEN-LOOP GAIN, DC Open-Loop Voltage Gain	$R_L \geq 2k\Omega$	$113^{(3)}$	120		dB
RATED OUTPUT Voltage Output Short Circuit Current	$R_L = 2k\Omega$ $V_O = 0VDC$	$\pm 11.0^{(3)}$	± 13.4 25		V mA
TEMPERATURE RANGE Specification		-40		+85	$^\circ C$

NOTES: (1) Offset voltage specification are measured with automatic test equipment after approximately 0.5s from power turn-on. (2) Unnulled or nulled with 8k Ω to 20k Ω potentiometer. (3) This parameter guaranteed by design.

ABSOLUTE MAXIMUM RATINGS

Supply Voltage	$\pm 22V$	<table border="1"> <thead> <tr> <th>PACKAGE TYPE</th> <th>θ_{JA}</th> <th>UNITS</th> </tr> </thead> <tbody> <tr> <td>8-Pin Plastic DIP (P)</td> <td>100</td> <td>$^\circ C/W$</td> </tr> <tr> <td>8-Pin SOIC (U)</td> <td>160</td> <td>$^\circ C/W$</td> </tr> </tbody> </table>	PACKAGE TYPE	θ_{JA}	UNITS	8-Pin Plastic DIP (P)	100	$^\circ C/W$	8-Pin SOIC (U)	160	$^\circ C/W$
PACKAGE TYPE	θ_{JA}		UNITS								
8-Pin Plastic DIP (P)	100	$^\circ C/W$									
8-Pin SOIC (U)	160	$^\circ C/W$									
Internal Power Dissipation ⁽¹⁾	500mW										
Input Voltage	$\pm V_{CC}$										
Output Short-Circuit Duration ⁽²⁾	Indefinite										
Differential Input Voltage ⁽³⁾	$\pm 0.7V$										
Differential Input Current ⁽³⁾	$\pm 25mA$										
Storage Temperature Range	$-55^\circ C$ to $+125^\circ C$										
Operating Temperature Range	$-40^\circ C$ to $+85^\circ C$										
Lead Temperature:											
P (soldering, 10s)	$+300^\circ C$										
U (soldering, 3s)	$+260^\circ C$										

NOTES: (1) Maximum package power dissipation vs ambient temperature. (2) To common with $\pm V_{CC} = 15V$. (3) The inputs are protected by back-to-back diodes. Current limiting resistors are not used in order to achieve low noise. If differential input voltage exceeds $\pm 0.7V$, the input current should be limited to 25mA.



ELECTROSTATIC DISCHARGE SENSITIVITY

This integrated circuit can be damaged by ESD. Burr-Brown recommends that all integrated circuits be handled with appropriate precautions. Failure to observe proper handling and installation procedures can cause damage.

ESD damage can range from subtle performance degradation to complete device failure. Precision integrated circuits may be more susceptible to damage because very small parametric changes could cause the device not to meet its published specifications.

The information provided herein is believed to be reliable; however, BURR-BROWN assumes no responsibility for inaccuracies or omissions. BURR-BROWN assumes no responsibility for the use of this information, and all use of such information shall be entirely at the user's own risk. Prices and specifications are subject to change without notice. No patent rights or licenses to any of the circuits described herein are implied or granted to any third party. BURR-BROWN does not authorize or warrant any BURR-BROWN product for use in life support devices and/or systems.

CONNECTION DIAGRAMS

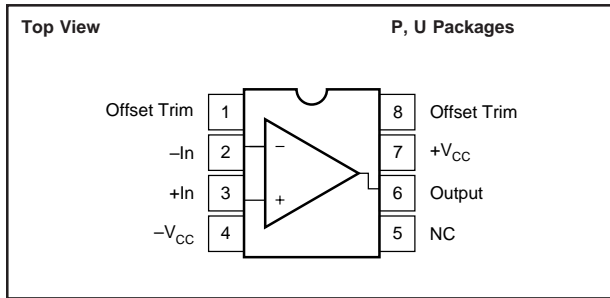

PACKAGE/ORDERING INFORMATION

PRODUCT ⁽¹⁾	PACKAGE	TEMPERATURE RANGE (°C)	OFFSET VOLTAGE MAX (μV), 25°C	PACKAGE DRAWING NUMBER ⁽³⁾
OPA27GP	Plastic	-40 to +85	±100	006
OPA27GU ⁽²⁾	SOIC	-40 to +85	±100	182

NOTE: (1) Packages for OPA37 are same as for OPA27. (2) OPA27GU may be marked OPA27U. Likewise, OPA37GU may be marked OPA37U. (3) For detailed drawing and dimension table, please see end of data sheet, or Appendix C of Burr-Brown IC Data Book.

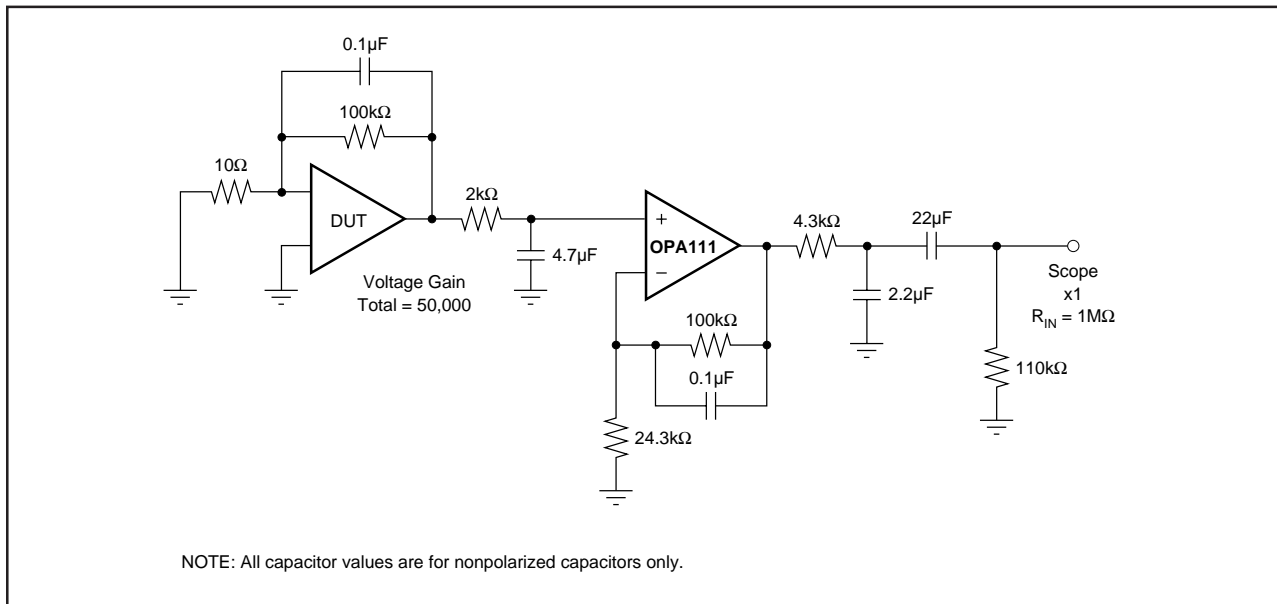

FIGURE 1. 0.1Hz to 10Hz Noise Test Circuit.

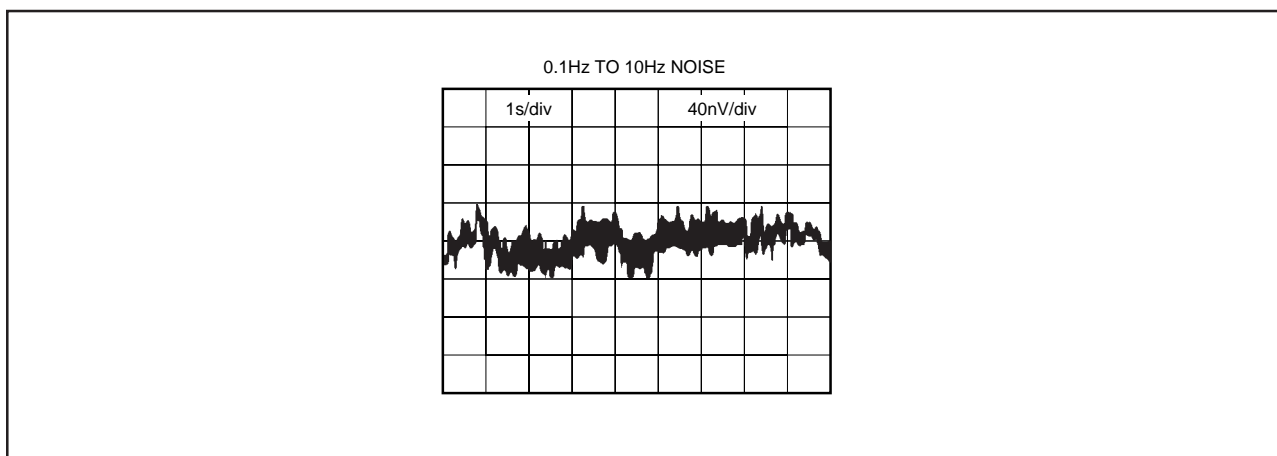
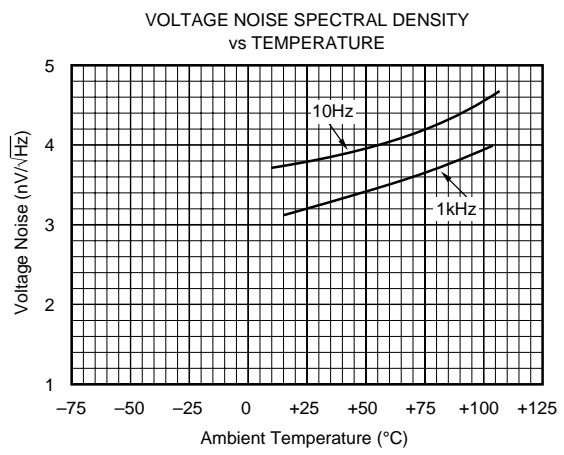
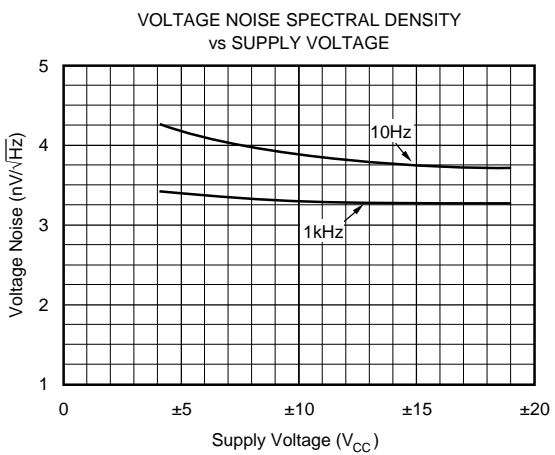
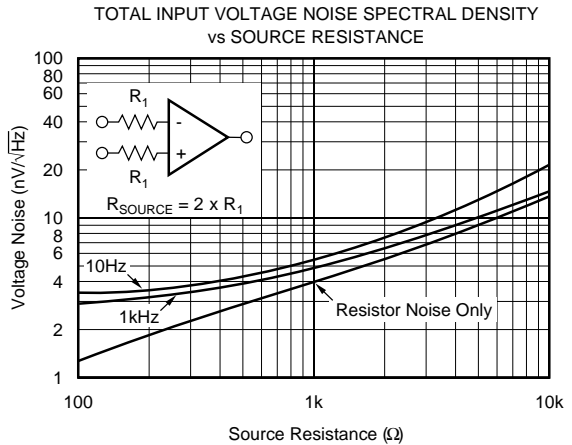
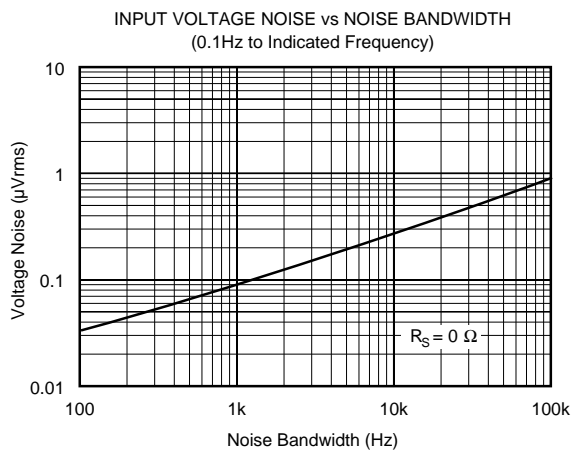
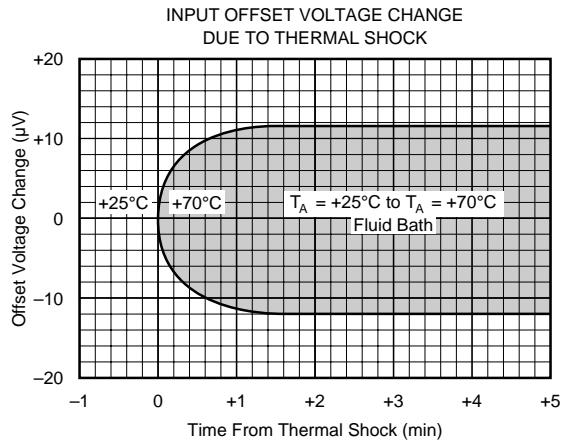
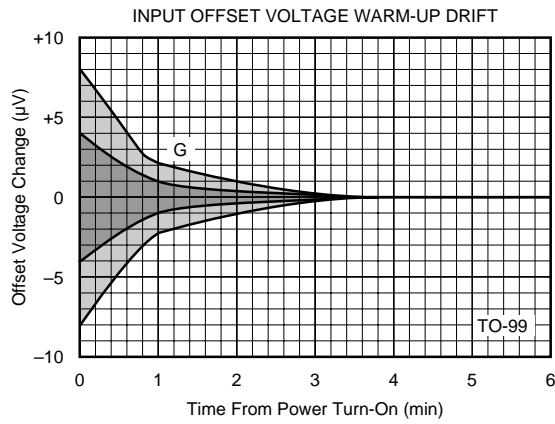

FIGURE 2. Low Frequency Noise.

TYPICAL PERFORMANCE CURVES

At $T_A = +25^\circ\text{C}$, $\pm V_{CC} = \pm 15\text{VDC}$, unless otherwise noted.



TYPICAL PERFORMANCE CURVES (CONT)

At $T_A = +25^\circ\text{C}$, $\pm V_{CC} = \pm 15\text{VDC}$, unless otherwise noted.

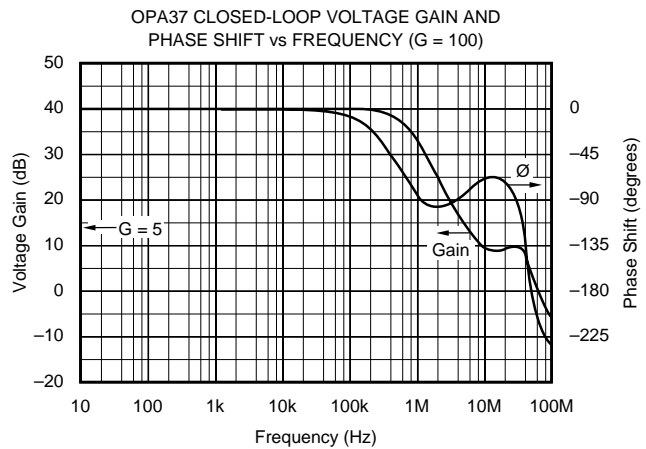
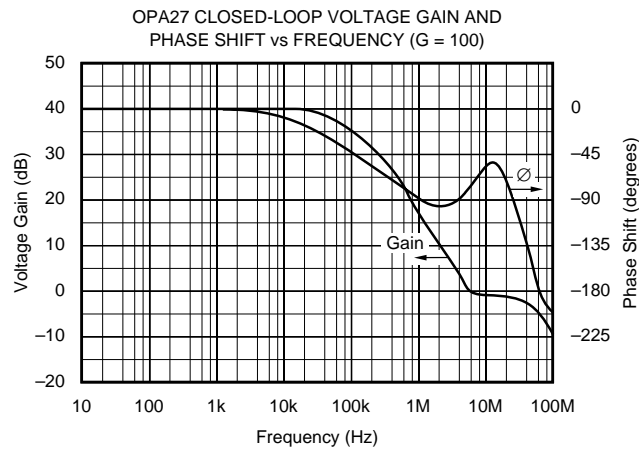
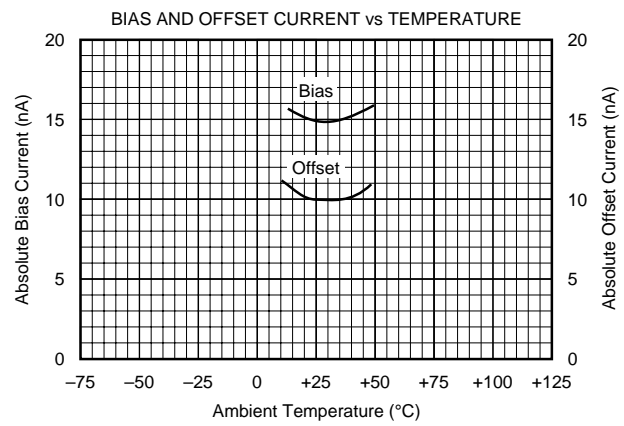
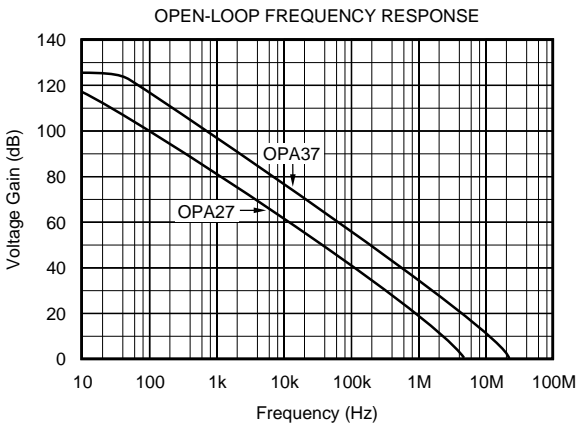
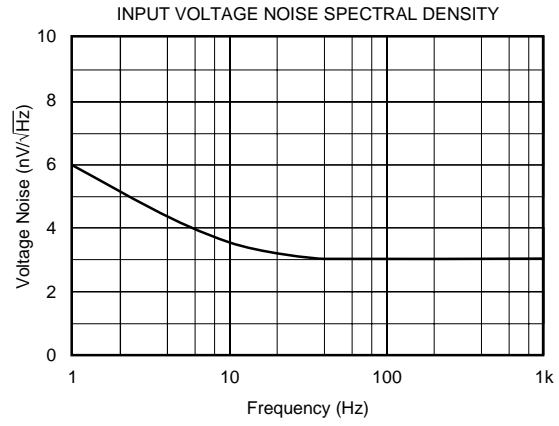
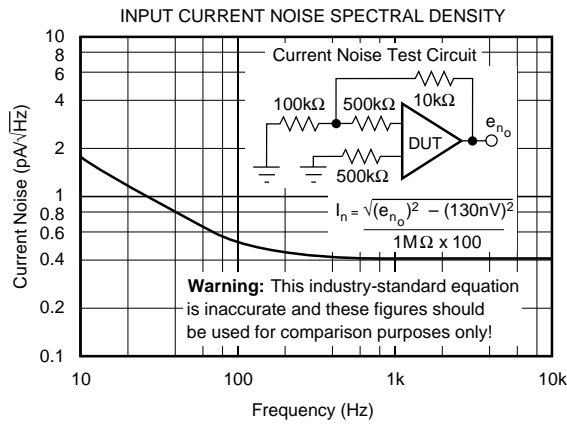

TYPICAL PERFORMANCE CURVES (CONT)

At $T_A = +25^\circ\text{C}$, $\pm V_{CC} = \pm 15\text{VDC}$, unless otherwise noted.

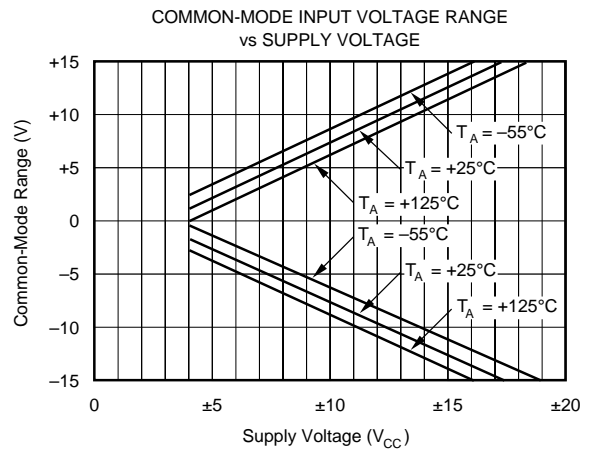
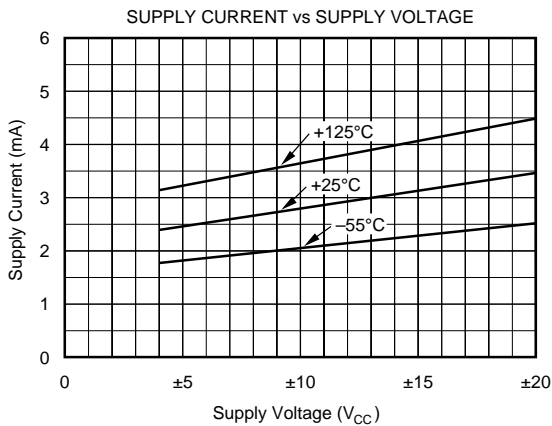
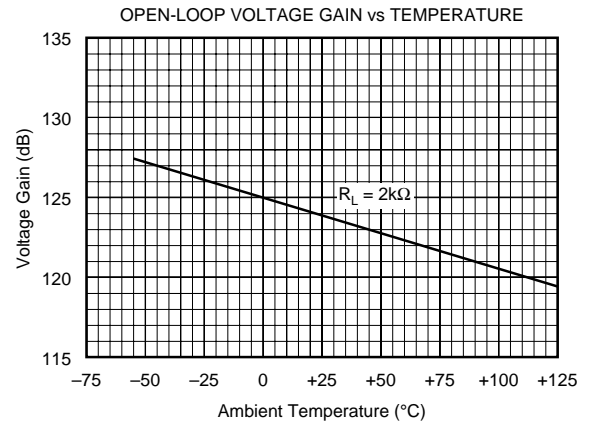
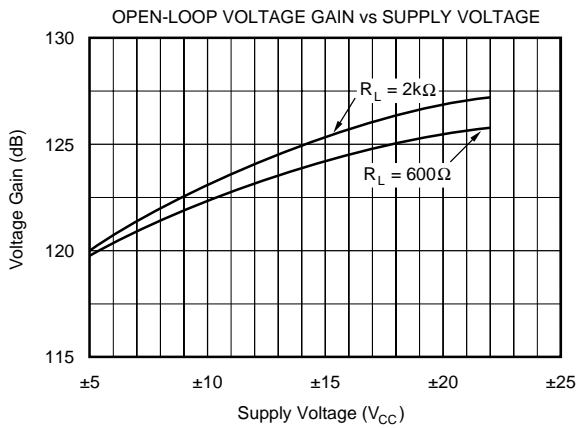
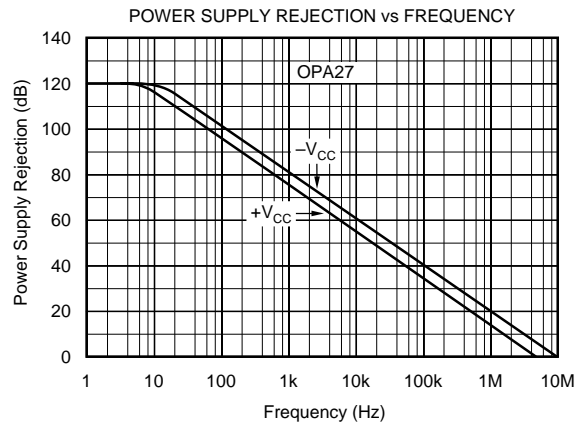
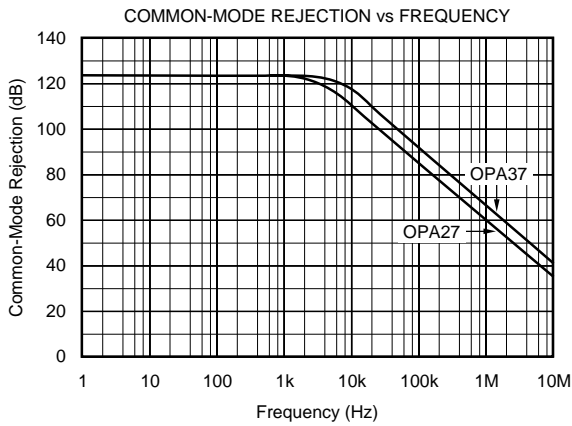

TYPICAL PERFORMANCE CURVES (CONT)

At $T_A = +25^\circ\text{C}$, $\pm V_{CC} = \pm 15\text{VDC}$, unless otherwise noted.

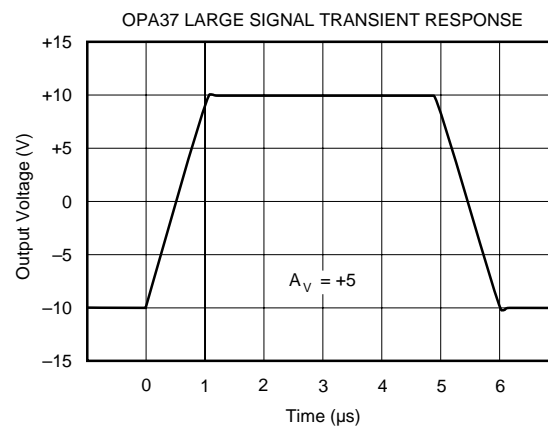
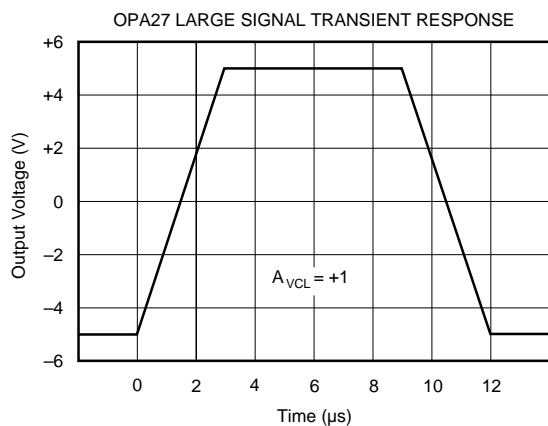
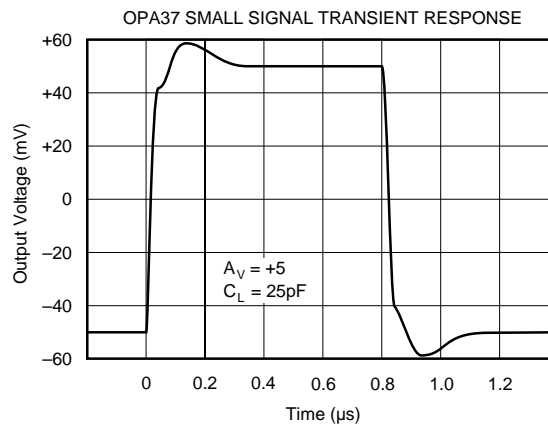
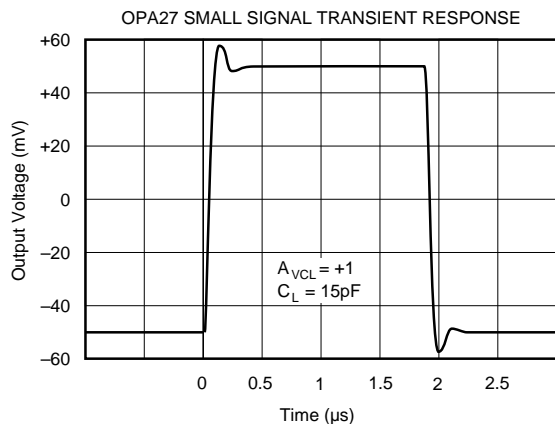

APPLICATIONS INFORMATION

OFFSET VOLTAGE ADJUSTMENT

The OPA27/37 offset voltage is laser-trimmed and will require no further trim for most applications. Offset voltage drift will not be degraded when the input offset is nulled with a $10\text{k}\Omega$ trim potentiometer. Other potentiometer values from $1\text{k}\Omega$ to $1\text{M}\Omega$ can be used but V_{OS} drift will be degraded by an additional 0.1 to $0.2\mu\text{V}/^\circ\text{C}$. Nulling large system offsets by use of the offset trim adjust will degrade drift performance by approximately $3.3\mu\text{V}/^\circ\text{C}$ per millivolt of offset. Large system offsets can be nulled without drift degradation by input summing.

The conventional offset voltage trim circuit is shown in Figure 3. For trimming very small offsets, the higher resolution circuit shown in Figure 4 is recommended.

The OPA27/37 can replace 741-type operational amplifiers by removing or modifying the trim circuit.

THERMOELECTRIC POTENTIALS

The OPA27/37 is laser-trimmed to microvolt-level input offset voltage and for very low input offset voltage drift.

Careful layout and circuit design techniques are necessary to prevent offset and drift errors from external thermoelectric potentials. Dissimilar metal junctions can generate small EMFs if care is not taken to eliminate either their sources (lead-to-PC, wiring, etc.) or their temperature difference. See Figure 11.

Short, direct mounting of the OPA27/37 with close spacing of the input pins is highly recommended. Poor layout can result in circuit drifts and offsets which are an order of magnitude greater than the operational amplifier alone.

NOISE: BIPOLAR VERSUS FET

Low-noise circuit design requires careful analysis of all noise sources. External noise sources can dominate in many cases, so consider the effect of source resistance on overall operational amplifier noise performance. At low source impedances, the lower voltage noise of a bipolar operational amplifier is superior, but at higher impedances the high current noise of a bipolar amplifier becomes a serious liability. Above about 15kΩ the Burr-Brown OPA111 low-noise FET operational amplifier is recommended for lower total noise than the OPA27 (see Figure 5).

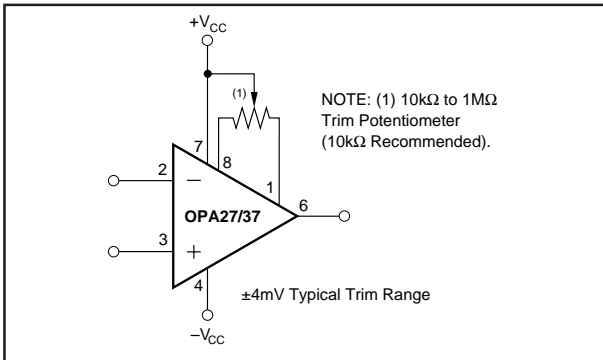

FIGURE 3. Offset Voltage Trim.

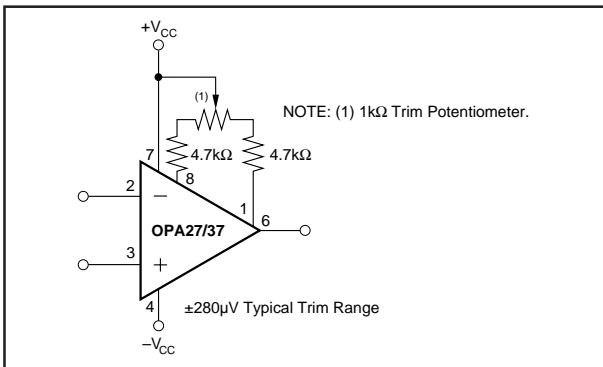

FIGURE 4. High Resolution Offset Voltage Trim.

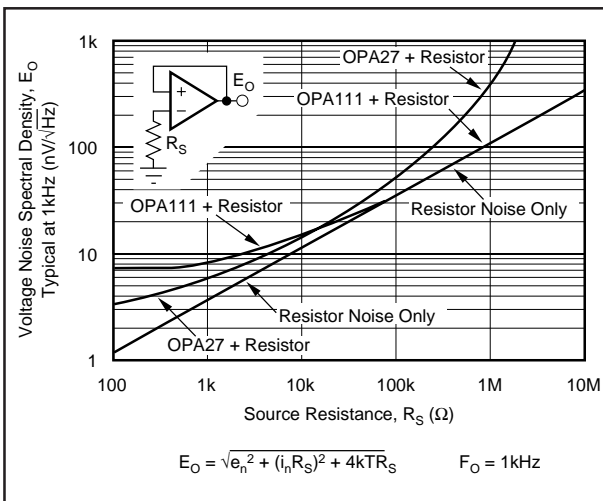

FIGURE 5. Voltage Noise Spectral Density Versus Source Resistance.

COMPENSATION

Although internally compensated for unity-gain stability, the OPA27 may require a small capacitor in parallel with a feedback resistor (R_F) which is greater than 2kΩ. This capacitor will compensate the pole generated by R_F and C_{IN} and eliminate peaking or oscillation.

INPUT PROTECTION

Back-to-back diodes are used for input protection on the OPA27/37. Exceeding a few hundred millivolts differential input signal will cause current to flow and without external current limiting resistors the input will be destroyed.

Accidental static discharge as well as high current can damage the amplifier's input circuit. Although the unit may still be functional, important parameters such as input offset voltage, drift, and noise may be permanently damaged as well as any precision operational amplifier subjected to this abuse.

Transient conditions can cause feedthrough due to the amplifier's finite slew rate. When using the OP-27 as a unity-gain buffer (follower) a feedback resistor of 1kΩ is recommended (see Figure 6).

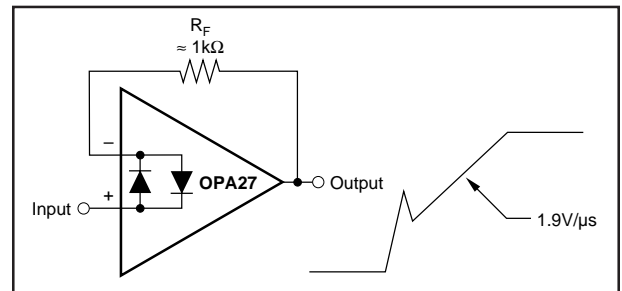

FIGURE 6. Pulsed Operation.

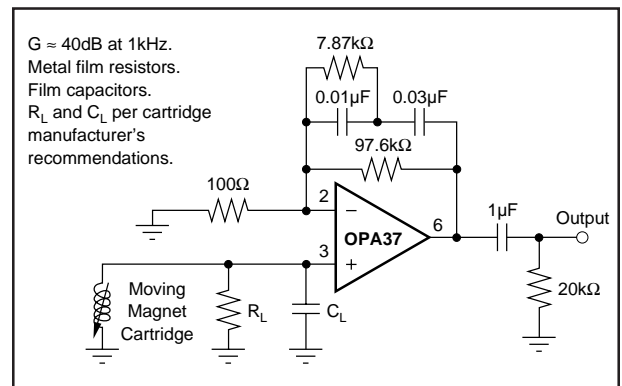

FIGURE 7. Low-Noise RIAA Preamplifier.

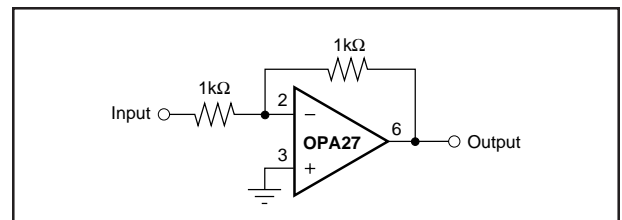

FIGURE 8. Unity-Gain Inverting Amplifier.

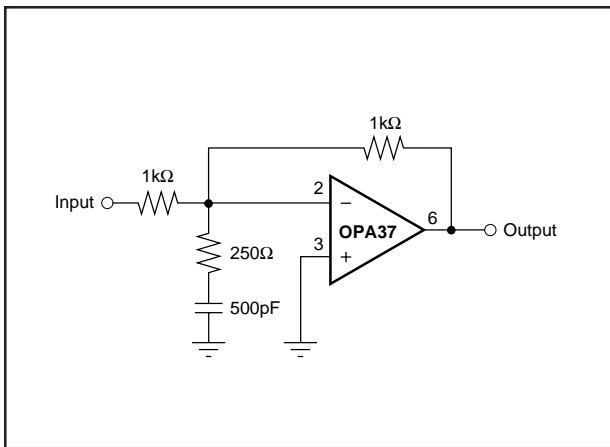

FIGURE 9. High Slew Rate Unity-Gain Inverting Amplifier.

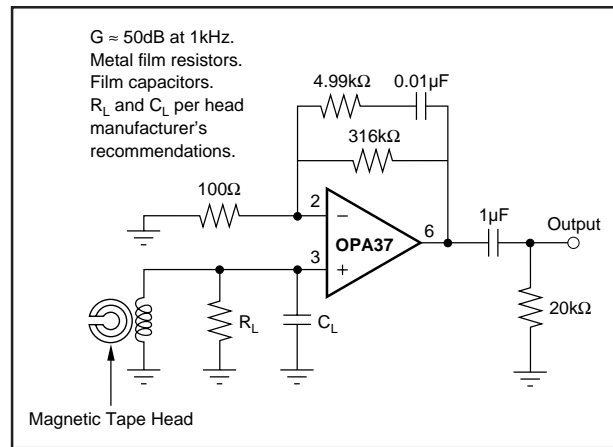

FIGURE 10. NAB Tape Head Preamplifier.

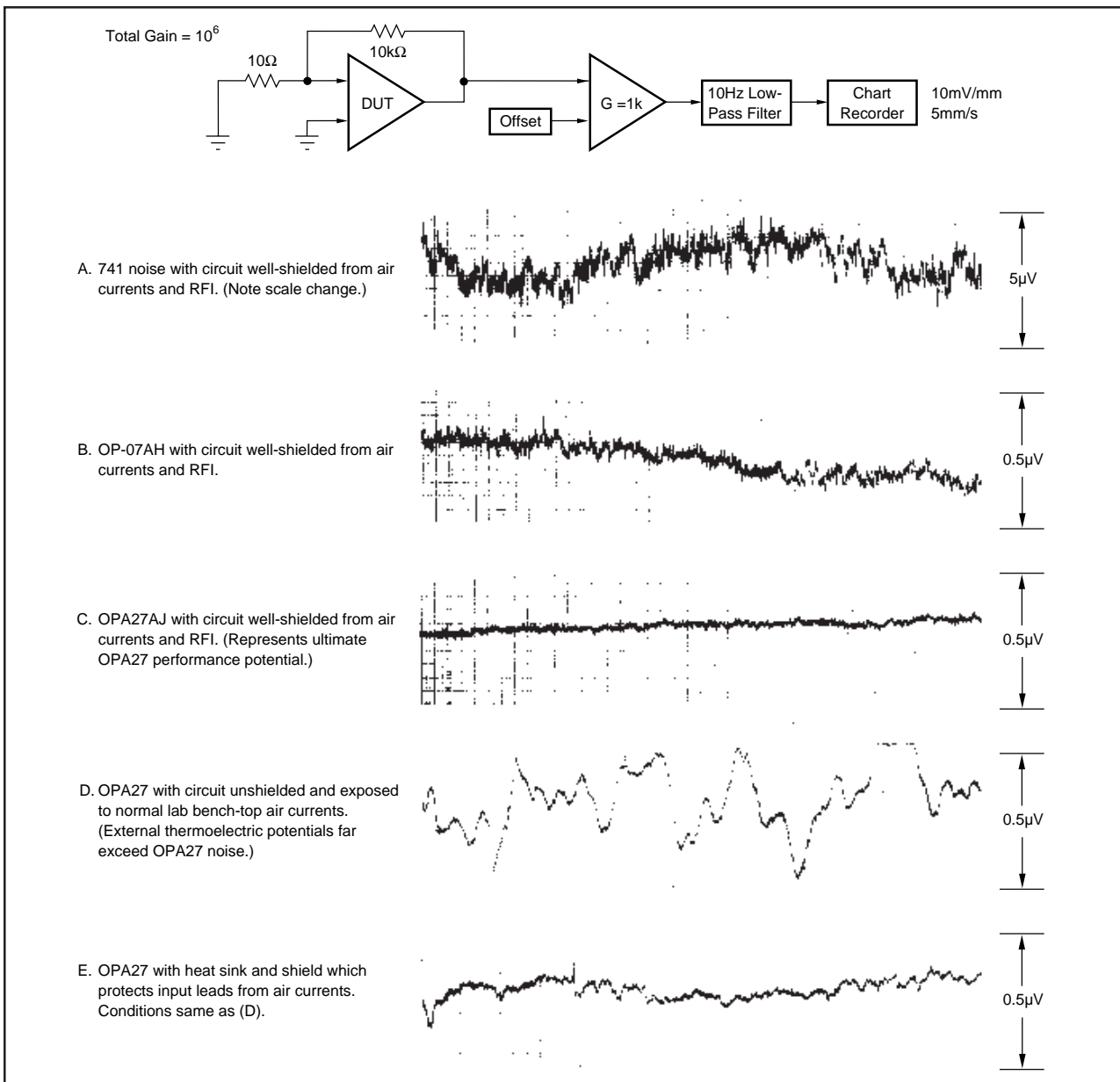

FIGURE 11. Low Frequency Noise Comparison.

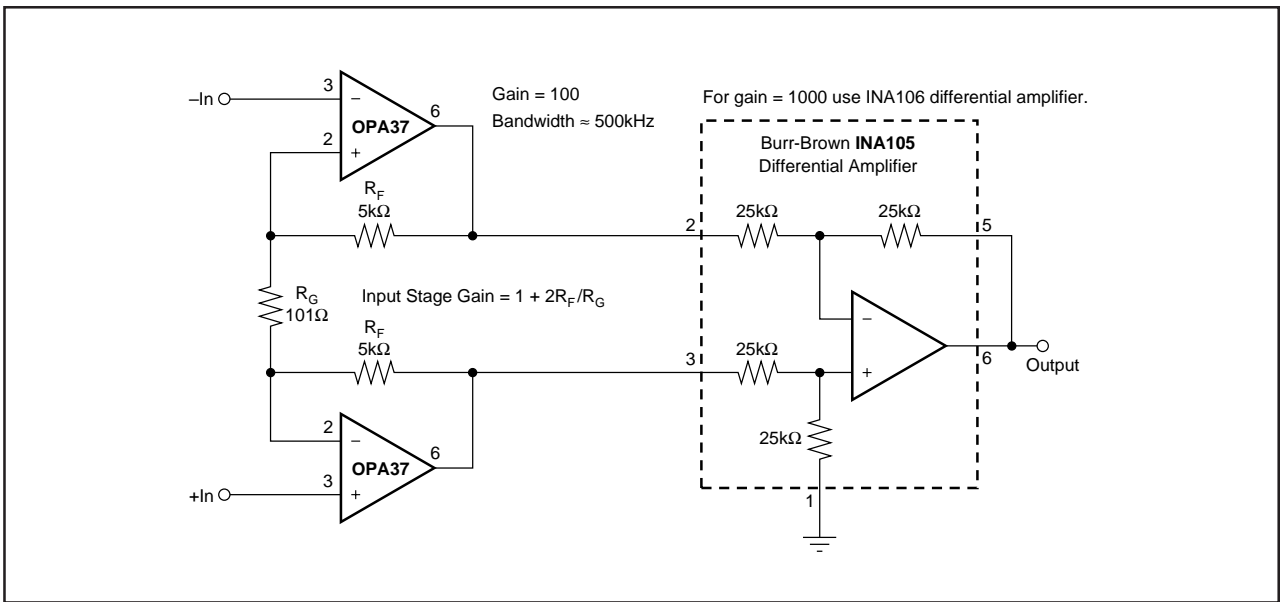

FIGURE 12. Low Noise Instrumentation Amplifier.

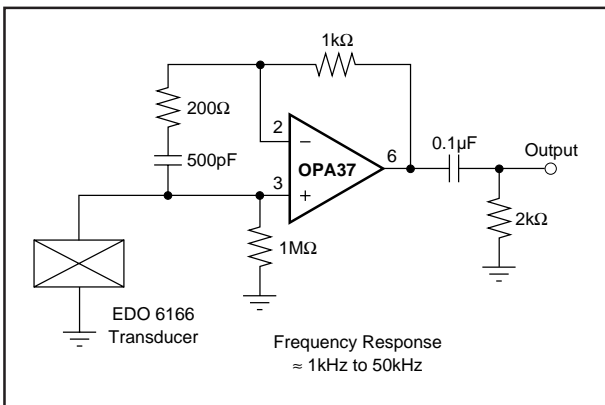

FIGURE 13. Hydrophone Pre-amplifier.

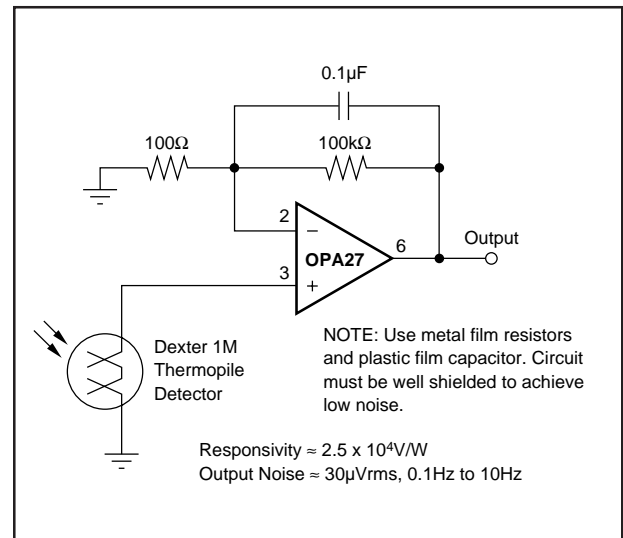

FIGURE 14. Long-Wavelength Infrared Detector Amplifier.

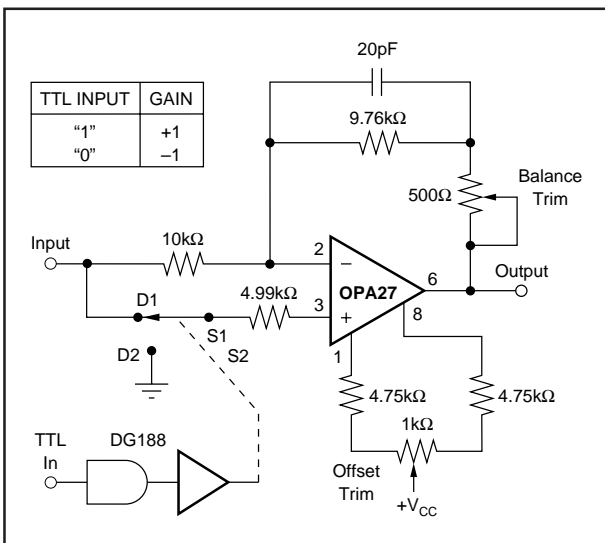

FIGURE 15. High Performance Synchronous Demodulator.

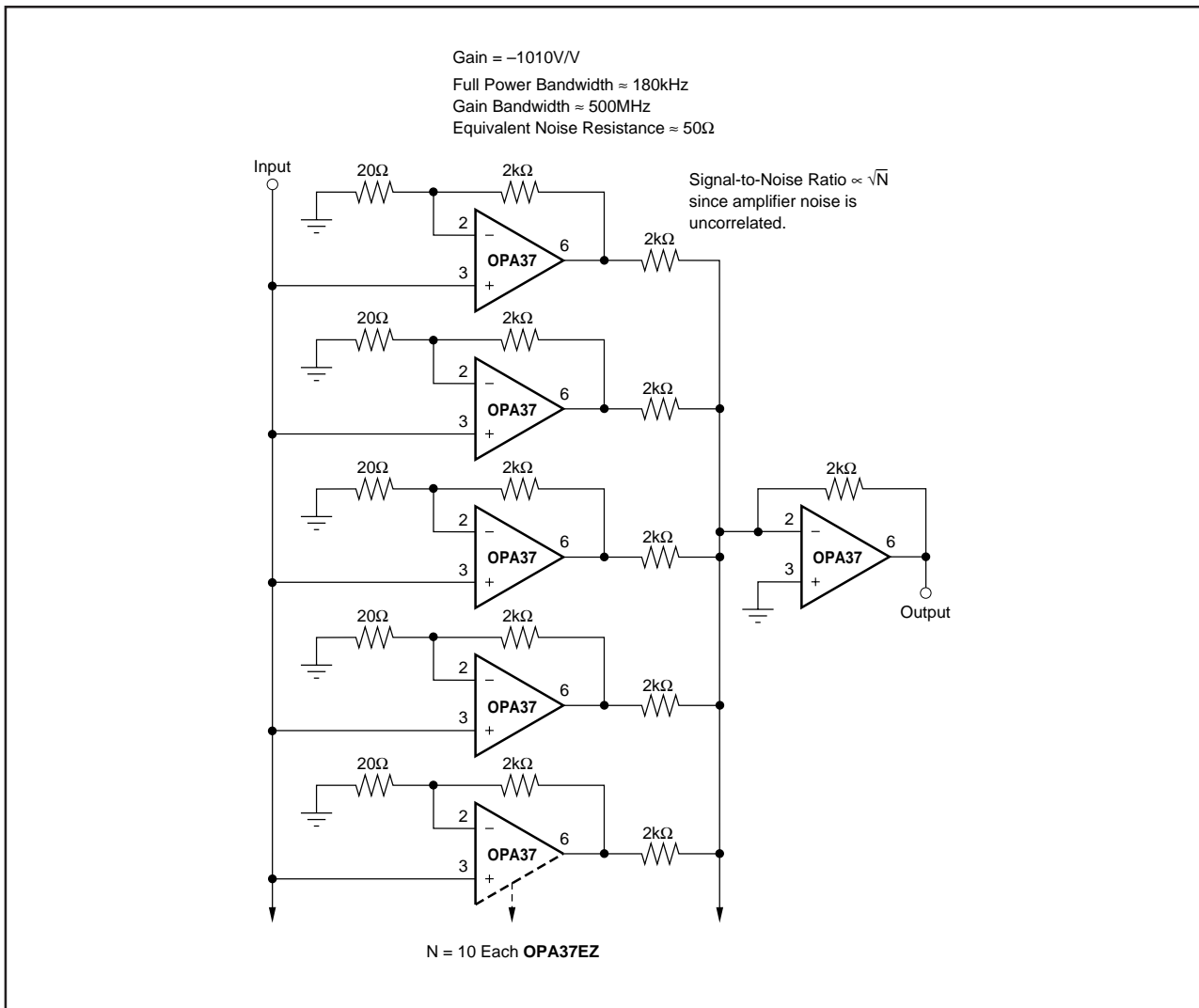

FIGURE 16. Ultra-Low Noise “N” Stage Parallel Amplifier.

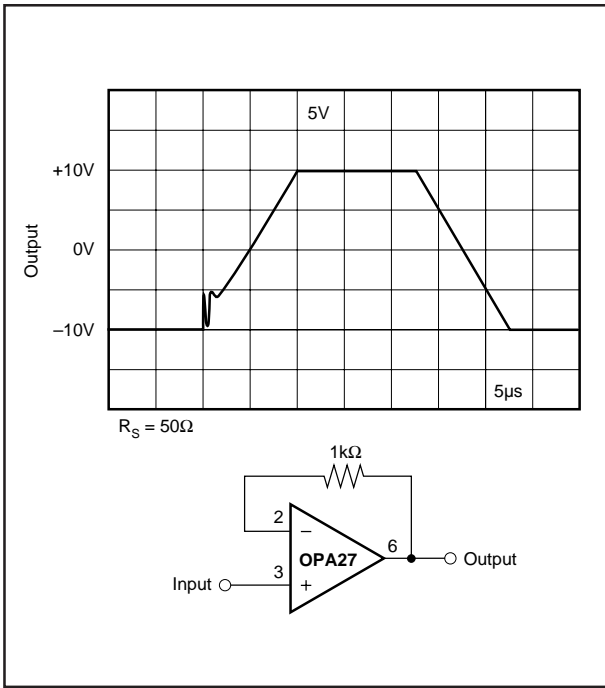

FIGURE 17. Unity-Gain Buffer.

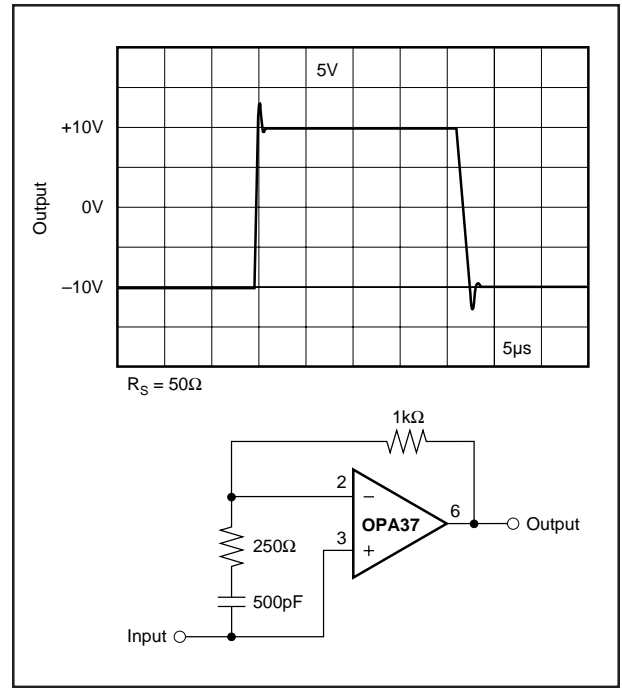

FIGURE 18. High Slew Rate Unity-Gain Buffer.

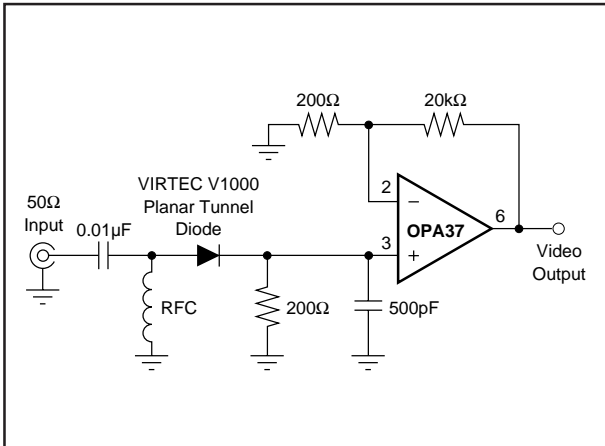

FIGURE 19. RF Detector and Video Amplifier.

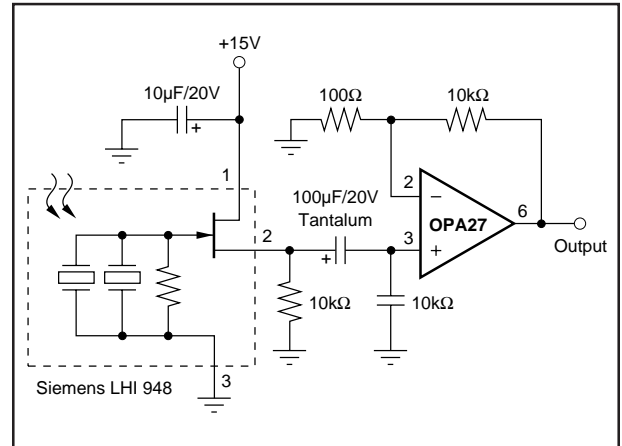

FIGURE 20. Balanced Pyroelectric Infrared Detector.

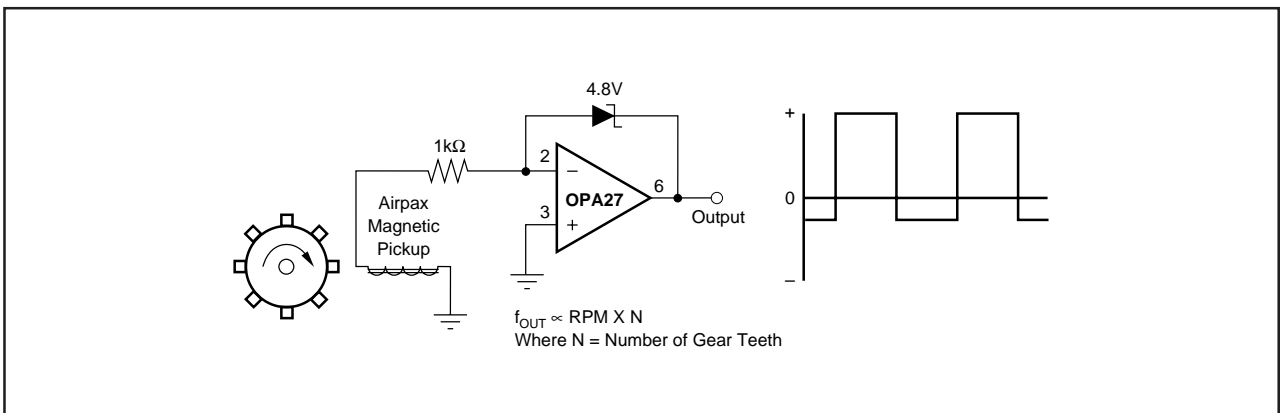

FIGURE 21. Magnetic Tachometer.